

**APPENDIX 4-U  
KSM WATER TREATMENT PLANT  
PROPOSED LAYOUT AND COSTS FOR  
SLUDGE DISPOSAL FACILITY**

---

# Memorandum



**DATE:** April 18, 2012  
**TO:** Clem Pelletier  
**FROM:** Gerry Papini  
**COPY:** Paul Greisman, Bob Askin  
**SUBJECT:** KSM Water Treatment Plant: Proposed Layout and Costs for Sludge Disposal Facility

---

Refer to File No.: Document1

## 1. Introduction

Acid Rock Drainage from the mine site area will be treated by lime neutralization with the precipitate thickened in High Density Sludge (HDS) thickeners. Rescan was asked by Seabridge to develop a process for further dewatering the sludge to produce a manageable dry filter cake. The sludge filter cake is to be stored in a landfill during the last 3 years of the construction phase of the project. It is assumed that during the operation phase, the sludge filter cake materials will be conveyed to the process plant with the ore, some 26 km away. The materials will then report to the ore stockpile and proceed through the mill for eventual storage in the tailings management facility. At closure the sludge will be stored on the waste rock dumps at the mine site. The design, operation and monitoring of the small landfill will provide a basis for the long term storage of the sludge during closure. Preliminary costs have been prepared for dewatering the sludge, warehousing the dehydrated material during the winter (7 months), as well as re-handling and disposing the material to a landfill during the summer. Photos taken at the Britannia Water Treatment Plant are provided at the end of this memo for illustrative purposes.

## 2. Sludge Dewatering and Storage

### 2.1 Dewatering and Storage during the last three years of 5 year construction period

Based on SGS's test work, the mass flow at the HDS thickener (20% solids w/w and 80% water concentration for the first ten years of operation), is estimated to be 100 tonnes per day of dry solids. This amount was adopted for design purposes. In addition, the clarifier underflow will have solids concentration of approximately 20%, with the specific gravity of the solids in the sludge of the clarifier underflow estimated at 1.8.

### 2.2 Proposed treatment and handling

Sludge from the HDS thickeners will be dewatered in standard plate filter presses producing a cake. The filter presses will be located in the water treatment plant building. During construction of the

project, the sludge will be stored between October 15<sup>th</sup> and May 15<sup>th</sup> and will be placed in a landfill for the remaining months. Stored filter cake will be re-handled and loaded on trucks for transport to the landfill during the summer season.

### **2.3 Agitated storage tanks**

The clarifier underflow will be stored in two 250 m<sup>3</sup> agitated storage tanks for feed to the plate filter presses. The tanks will be designed to hold 1 days' worth of clarifier underflow. The HDS sludge in the tanks will be pumped to the filter presses for dewatering.

### **2.4 Filter Presses**

The projected HDS underflow to the filter press is a maximum of 19 m<sup>3</sup>/hr or 456m<sup>3</sup>/day. The filter presses will be operated at a rate of 45 to 55m<sup>3</sup>/hour for 8-10 hours during a 24 hour period. Two filter presses will be required with a third filter press on standby; thus a total of three filter presses are required. Each press will contain approximately 80 plates for solids filtering. There will be two products leaving the filter press: water which will be returned to the process and a sludge cake which will be stored in a landfill or transported to the plant site on the ore conveyor.

The volume of cake depends upon the free water content. Assuming that the filter presses reduce water content from 80% to 40%, the 100 tonnes per day of dry of solids will produce 167 tonnes per day of filter cake. The SG of the cake is estimated to be approximately 1.4, so that 121 m<sup>3</sup>/day of filter cake will be produced (one cubic metre of filter cake which will have a mass of 1400 kg) per day. The filter presses will be elevated, and the filter cake would drop from the presses into the box of an end dump truck. The truck will transport the filter cake either to the landfill in summer or to the covered storage area in winter. During operations the filter cake will be transported by truck and deposited on the ore conveyor belt located at the tunnel entrance.

### **2.5 Winter Storage Building**

Winter storage will be required for 7 months or 212 days of production. This period requires approximately 25,700 m<sup>3</sup> of filter cake storage capacity. The filter cake will be end dumped on the floor of the building and stacked with a wheeled loader. A dry storage building capable of accommodating at least 25,700 m<sup>3</sup> of filter cake stacked up to 3.0 m high will require a foot print of 8,700 m<sup>2</sup>. The area would be enclosed within a "Sprung" building measuring 30 m X 328 m. See attached Figures 1 and 2. The Sprung™ building could be located adjacent to and upslope of the water treatment plant. See Figure 3 for a layout of the sludge storage building.

It might be desirable to heat the building to prevent freezing of the cake, but at this time we have not included the cost of heating. The roof will need to shed snow and the 26 degree slopes of the Sprung buildings are specifically designed for this purpose.

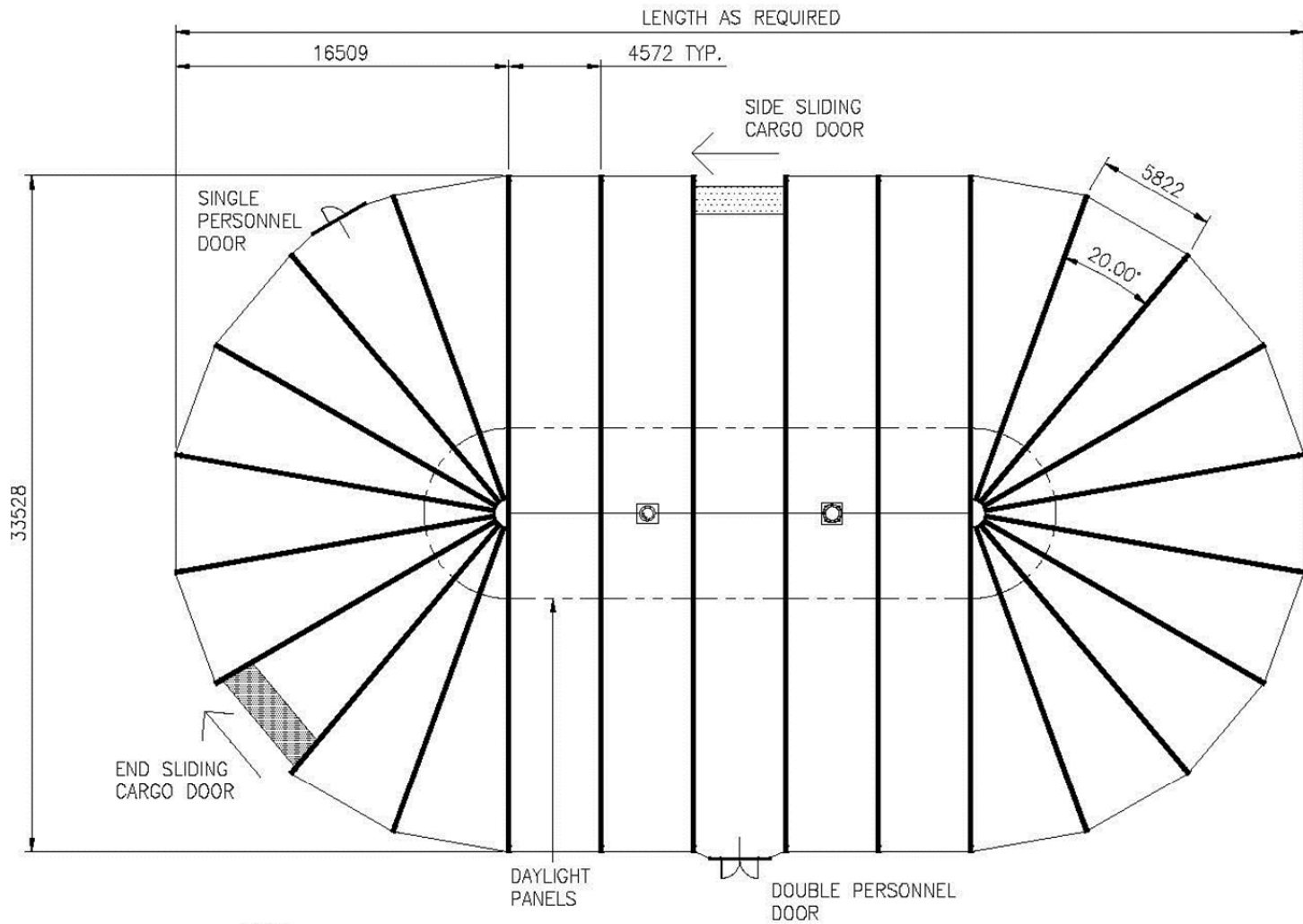
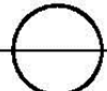

Figure 1

**PLAN VIEW**  
 1:300



SIGNATURE SERIES

<b>33.5m WIDE STRUCTURE W/ROUND ENDS 4.5m OC</b>	
DATE 03/23/2012	SCALE AS NOTED
DRAWING # 110 RE SALES METRIC A	

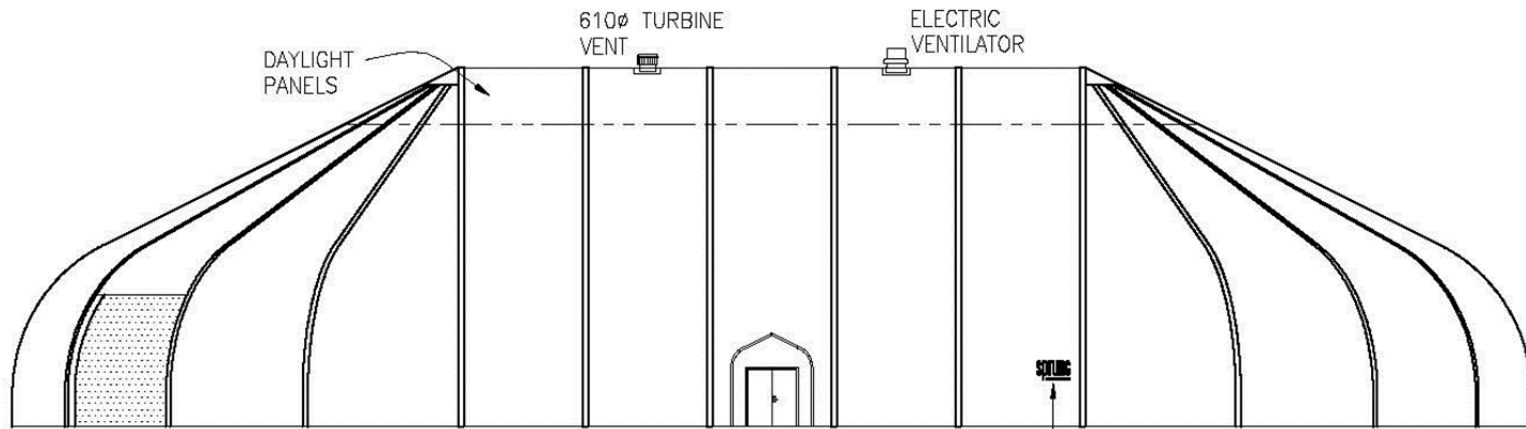

 **ELEVATION**  
1:250

- THE FOLLOWING DOORS ARE AVAILABLE AT EXTRA CHARGE:
- SINGLE PERSONNEL DOOR 914w x 2134h (C/W 3048 HOOD)
  - DOUBLE PERSONNEL DOOR 1829w x 2134h (C/W 3048 HOOD)
  - SIDE SLIDING CARGO DOOR 4369w x 5486h
  - END SLIDING CARGO DOOR TOP 4877w, BASE 5512w x 5486h
  - DOUBLE PANEL ROLLING DOOR TOP 2743w,  
BASE 11074w x 10719h (SEE DPRD-110)
  - TRIPLE PANEL ROLLING DOOR TOP 3785w,  
BASE 16281w x 10897h (SEE TPRD-110)
  - QUADRUPLE PANEL ROLLING DOOR TOP 4928w,  
BASE 21006w x 10897h (SEE TPRD-110)

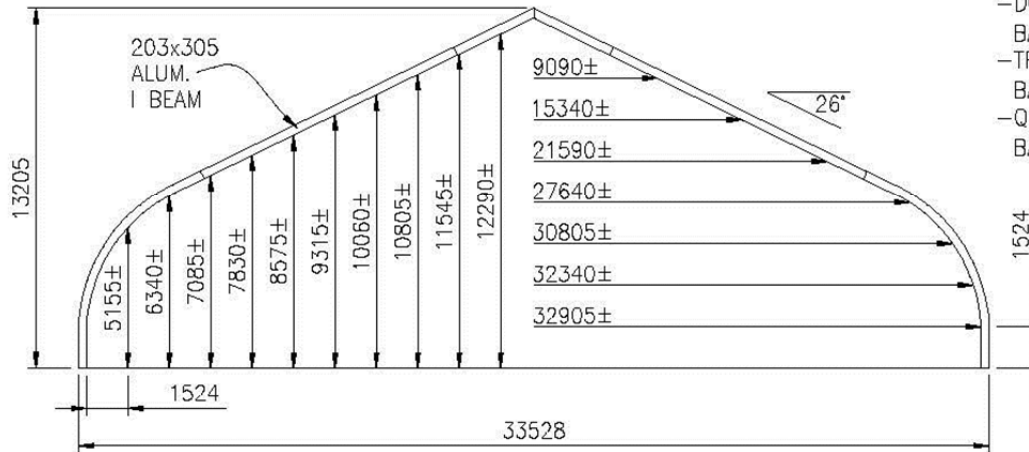

 **SECTION 33.5m STRUCTURE**  
1"=20'-0"

Figure 2



**33.5m WIDE  
STRUCTURE W/ROUND ENDS  
4.5m OC**

DATE: 03/23/2012 SCALE: AS NOTED

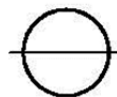
DRAWING # 110 RE SALES METRIC B

SIGNATURE SERIES



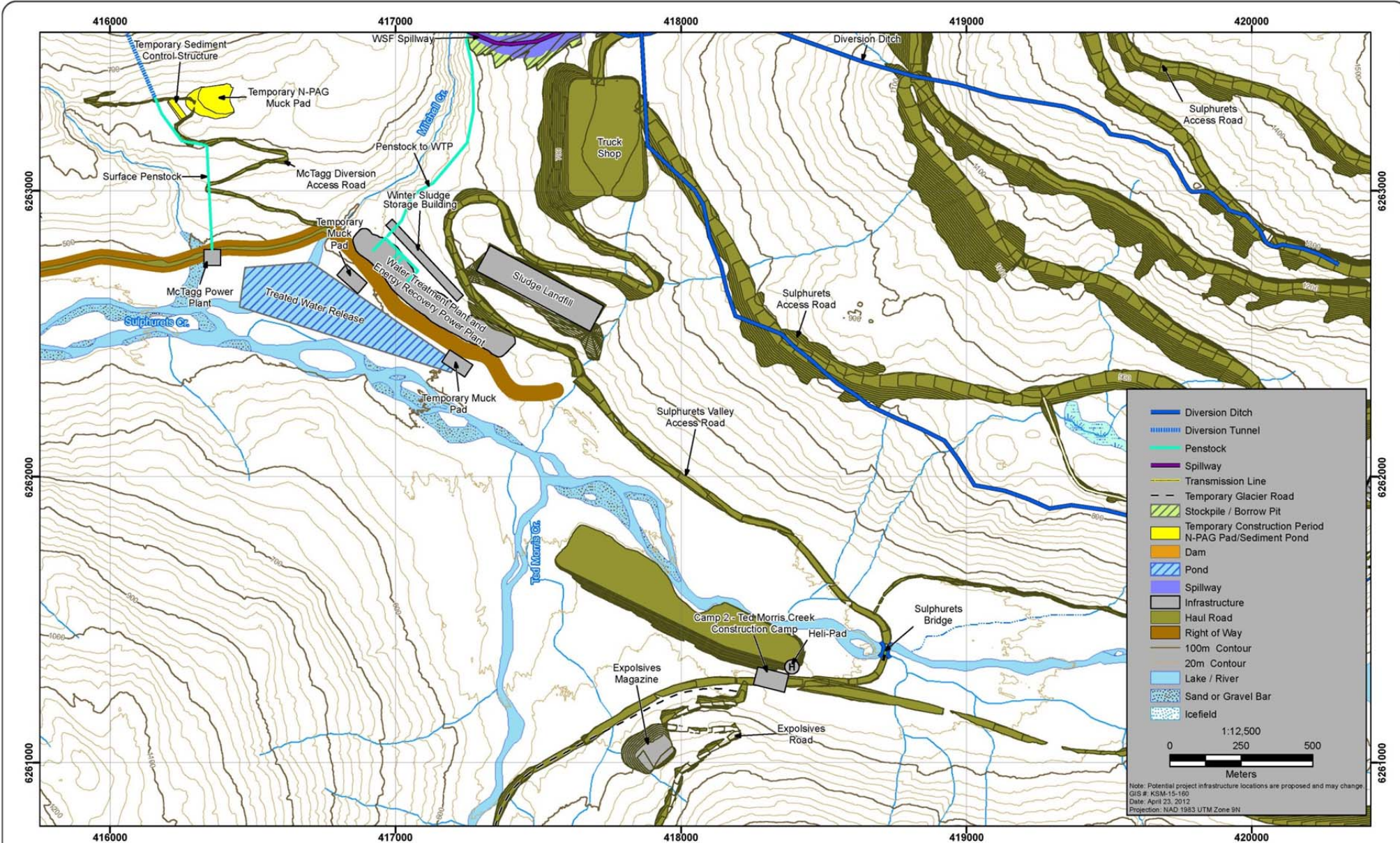

Note: Potential project infrastructure locations are proposed and may change  
 GIS # KSM-15-160  
 Date: April 23, 2012  
 Projection: NAD 1983 UTM Zone 9N

### 3. Sludge Disposal

The sludge will be disposed of in a proposed landfill structure that has been designed to accommodate three years of sludge production or about 135,000 m<sup>3</sup> in total. The planned landfill design is based on the following dimensions: a length of 450 m, a width of 110 m and final height of approximately 9.5 m. This includes a 1.0 m compacted foundation base, three lifts of 2.5 m deep composite fill layers, as well as a closure cover of 1 m (see Figures 4 and 5). The estimated volumes and areas of the landfill materials are listed in Table 1.

Table 1: Volume of Landfill Construction Materials

Construction Material	Volume (m <sup>3</sup> )	Area (m <sup>2</sup> )
Filter Cake	135,500	
Colluvium / Till (landfill between cake)	48,000	
Sand (liner bedding and cover material)	56,000	
Landfill Base (compacted colluvium / till)	51,200	
Filter (gravel) material	3,500	
Waste rock (NPAG)	37,500	
Cover (closure) material	55,000	
Geogrid	n/a	100,000
Geomembrane	n/a	100,000

The conceptual layout for the sludge disposal will be located on the hillside upslope of the water treatment plant (Figure 3). Approximately 5 m of colluvium material is anticipated in this area (Frontier Geoscience seismic survey), so some rock excavation will be required to establish the site. The slope has up to 20% gradient in this area. The landfill base should be gently inclined (~2%) to limit ponding. The base of the landfill will comprise a 1m-thick base of compacted colluvium/till or bedrock. The landfill will be constructed with 2.5m-high NPAG (non-acid generating) waste rock lifts. The lifts are specified at 3:1 slope on the downstream side and 1:1 slope on the upstream side but this may change as a result of geotechnical engineering assessment. The waste rock should be screened to exclude very large pieces (e.g. >500 mm) and compacted with a vibratory roller. A filter (gravel) layer is proposed (at ~ 0.5 m thick) on the upslope face between the waste rock and the filter cake / colluvium fill materials (see Figures 4 and 5).

The sludge filter cake stored in the Sprung™ building, as well as ongoing production from the WTP will be trucked to the landfill site during the five month summer period. It will then be dumped and spread with a wide track Dozer (Cat D6) in lifts not greater than 0.7 m. The inter-bedded 0.5 m-thick granular layer (till mix / colluvium) will subsequently be spread over the sludge filter cake layer and nominally compacted (roller) before adding the second filter cake (0.7 m-thick) layer.

# Plan View

(Access Routes Not Shown)

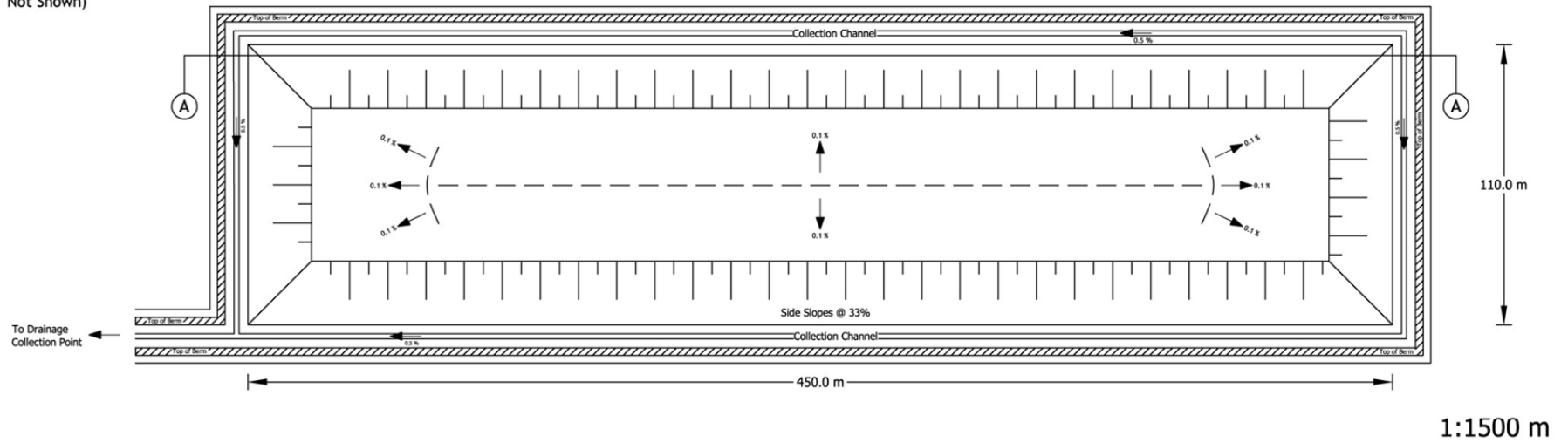

# Section A-A

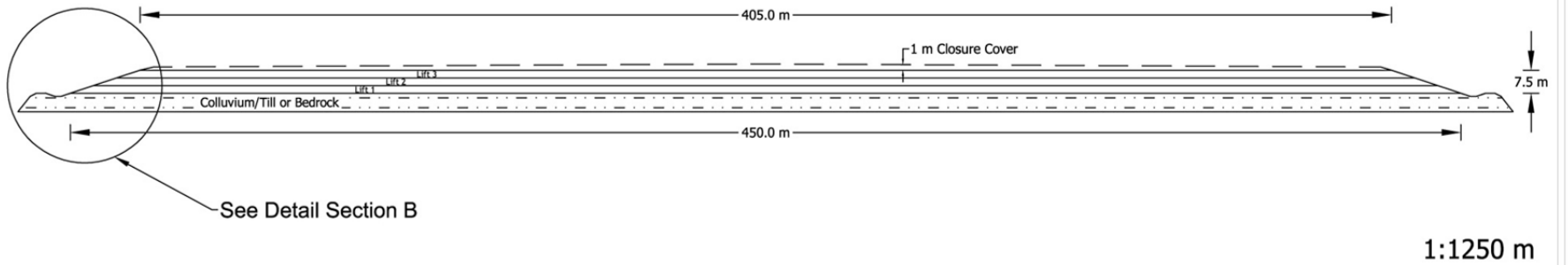

Kerr-Sulpurets  
-Mitchell Project

SEABRIDGE GOLD

KSM Water Treatment Plant Sludge  
Management

This drawing is for planning purposes only. Not responsible for any design and construction completed by others

SCALE:  
As Shown

Figure 4

DATE:  
April 18, 2012

TITLE:

Conceptual Layout for  
Landfill Structure - Plan  
View and Section A-A





Compaction of the sludge filter cake layers (in addition to dozer tracking activities) may not be advisable because of potential liquefaction or other unforeseen physical changes to the material. A geogrid reinforcement layer has been provided to increase the shear strength and load bearing capacity of the sludge filter cake layers (if necessary). Further geotechnical engineering evaluation of the physical properties and load bearing capacity of the sludge filter cake materials is recommended (see Figure 5).

The landfill is designed to accommodate approximately 45,000 m<sup>3</sup> of sludge filter cake each year in two 0.7m lifts with an inter-bedded 0.5m-thick granular layer for strength (Figure 4). Since the composition of the filter cake will consist of a potentially soluble materials (metal hydroxides and gypsum respectively), water management within the landfill is expected to be important. Each year the landfill will be 'closed' for the winter period by covering the landfilled materials with a geomembrane to exclude moisture penetration. The geomembrane (e.g. HDPE) will be installed on a 300 mm bedding layer (sand) and covered with a further 300 mm of cover material (sand) to conclude the annual landfilling operation. A geogrid is also proposed to provide overall strength and trafficability on the landfill.

Accumulated snow will need to be managed during spring melt. An open channel at the toe of the deposit will be built to convey run-off towards the WTP. Closure of the facility has not been determined, but should include re-use of stockpiled soil and colluvium to reclaim the surface and slopes of the facility. At this time, a 1.0 m-thick soil cover has been included in the conceptual layout for costing purposes (see Figures 4 and 5).

The fill structure could be instrumented with settlement plates, strain gauges, and vibrating wire piezometers etc. to assess the performance of the sludge materials over time. Piezometers should be installed down gradient of the landfill to monitor the effect of any seepage to groundwater quality.

#### **4. Preliminary Costs**

Preliminary capital and annual operating costs have been prepared using estimated values from suppliers, calculated cut-and-fill volumes, as well as professional judgement (Table 2). Capital costs include filter presses and support structures; Sprung™ building and erection costs; a loader, dozer and three 10 tonne trucks; landfill preparation and material costs; open channel to convey run-off to the WTP, as well as closure costs. Operating costs include manpower (including accommodation); parts, fuel, water quality monitoring and landfill instrumentation.

Table 2: Preliminary Capital and Operating (During Construction and Operation) Costs

<b>KSM Sludge filtering and storage costs</b>					
<b>Capital Costs</b>					
<b>ITEM</b>	<b>Quantity</b>	<b>Unit</b>	<b>unit cost</b>	<b>Item cost</b>	<b>Source</b>
Agitated sludge storage tanks 8 x 5	2	ea.	\$150,000	\$300,000	est.
Filter presses	3	ea.	\$350,000	\$1,050,000	Fox fluid power
Filter press hopper and support structure	3	ea.	\$50,000	\$150,000	MM
Site prep for Sprung building	50,000	m3	\$6	\$300,000	Rescan
Sprung building for 7 mo. storage	1	ea.	\$3,371,604	\$3,371,604	Sprung
Erection of Sprung building 24 men, 92 days	17,664	hours	\$100	\$1,766,400	Sprung, MM
Shipping	1	lot	\$59,500	\$59,500	Sprung
Accommodation for erection crew	2,208	days	\$260	\$574,080	Highway camp rate
Lock blocks and paving	1	lot	\$200,000	\$200,000	Rescan
Loader at storage building	1	ea.	\$178,000	\$178,000	CAT 930 H
Trucks to haul filter cake	3	ea.	\$200,000	\$600,000	est.
Site prep for landfill (450 x 110 m)					
Soil strip and stockpile	272,250	m3	\$2	\$544,500	area plus 10%, 5 m thick colluvium
Cut	225,000	m3	\$10	\$2,250,000	volume Moose Mountai, rate Rescan
Fill	284,000	m3	\$6	\$1,704,000	volume Moose Mountain rate Rescan
Colluvial till - place, spread and roll	51,200	m3	\$6	\$307,200	Rescan
Berm - 2.5 m waste rock lifts and compact	37,500	m3	\$10	\$375,000	Rescan
Sand - bedding layer / filter layer	56,000	m3	\$12	\$672,000	Rescan
Grave filter layer	3,500	m3	\$15	\$52,500	Rescan
Dozer at Landfill	1	ea.	\$295,000	\$295,000	CAT D6
Instrumentation including settlement plates, vibrating wires, etc..	1	lot	\$100,000	\$100,000	Rescan
Channel from landfill to WTP	1	ea.	\$250,000	\$250,000	Rescan
Closure Cost - colluvium place, spread and roll - landform	56,000	m3	\$10	\$560,000	Rescan
<b>TOTAL CAPITAL COST</b>				<b>\$15,659,784</b>	
<b>Operating costs</b>					
<b>DURING CONSTRUCTION</b>					
<b>ITEM</b>	<b>Annual q't'y</b>	<b>unit</b>	<b>unit cost</b>	<b>Annual Cost</b>	
Filter presses					
operator	3650	hrs./yr.	\$100	\$365,000	MM
parts	8%	capital		\$84,000	est.
Loader and Dozer operators	4137	hrs./yr.	\$100	\$413,667	MM
Loader, Dozer Fuel, maintenance	517	days	\$100	\$51,708	MM
Truck operators	5353	hrs./yr.	\$100	\$535,333	MM
Truck fuel maintenance	669	days	\$100	\$66,917	MM
Land fill yearly materials	1	lot	\$100,000	\$100,000	Rescan
Geogrid	33,000	m2	\$5	\$165,000	Rescan
Geomembrane 80 mil HDPE	33,000	m2	\$10	\$330,000	Rescan
Accommodations for operators	1643	days	\$260	\$427,050	Highway camp rate
Monitoring and analytical costs	1	lot	\$50,000	\$50,000	Rescan
<b>TOTAL ANNUAL OPERATING COST DURING CONSTRUCTION</b>				<b>\$2,588,675</b>	
<b>DURING OPERATIONS</b>					
Filter presses					
operator	3650	hrs./yr.	\$100	\$365,000	MM
parts	8%	capital		\$84,000	est.
Loader operator	2920	hrs./yr.	\$100	\$292,000	MM
Loader fuel, maintenance	365	days	\$100	\$36,500	MM
Truck operator (to conveyor)	2920	hrs./yr.	\$100	\$292,000	MM
Truck fuel maintenance	365	days	\$100	\$36,500	MM
Accommodations for operators	1186	days	\$260	\$308,425	Highway camp rate
Monitoring and analytical costs	1	lot	\$50,000	\$50,000	est.
<b>TOTAL ANNUAL OPERATING COST DURING OPERATION</b>				<b>\$1,464,425</b>	

Photos from Britannia Water Treatment Plant



*20 Plate Filter Press*



*Close-up Filter Press Plate Hangers*



*Filter Cake Off Press*

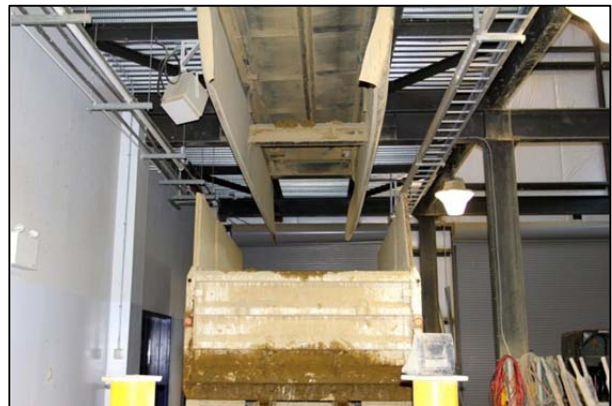

*Truck Under Filter Press Dumper*



*Filter Plate*



*Filter Cloth*



Photos from Britannia Water Treatment Plant



*Close-up of Filter Cake*



*Sludge Filter Cake: 40% Moisture*



*Sludge Storage Building at Britannia*



*Front View of Sludge Storage Building at Britannia*



*Truck Dump Load of Sludge*



*Sludge in Building at Britannia*