

Goliath Stakeholders Meeting



Norm Bush Vice President, Operations

Mark Wheeler, Sr. Mining Engineer

Murray Ferguson, Director of Community Development

Rory Krocker, Sr. Project Geologist

Mac Potter, Environmental Technician



FORWARD-LOOKING STATEMENTS

This presentation contains projections and forward-looking information that involve various risks and uncertainties regarding future events. Such forward-looking information can include without limitation statements based on current expectations involving a number of risks and uncertainties and are not guarantees of future performance of the Corporation. These risks and uncertainties could cause actual results and the Corporation's plans and objectives to differ materially from those expressed in the forward-looking information. Actual results and future events could differ materially from anticipated in such information. These and all subsequent written and oral forward-looking information are based on estimates and opinions of management on the dates they are made and expressly qualified in their entirety by this notice. The Corporation assumes no obligation to update forward-looking information should circumstances or management's estimates or opinions change. This presentation contains projections and forward looking information that involve various risks and uncertainties regarding future events. Such forward-looking information can include without limitation statements based on current expectations involving a number of risks and uncertainties and are not guarantees of future performance of the Corporation. These risks and uncertainties could cause actual results and the Corporation's plans and objectives to differ materially from those expressed in the forward-looking information. Actual results and future events could differ materially from anticipated in such information. These and all subsequent written and oral forward-looking information are based on estimates and opinions of management on the dates they are made and expressly qualified in their entirety by this notice. The Corporation assumes no obligation to update forward-looking information should circumstances or management's estimates or opinions change.



TREASURY METALS INC.



- **WHO WE ARE**
- **WHERE WE ARE**
- **PROJECT STATUS**
- **EMPLOYMENT OPPORTUNITIES**
- **JOB REQUIREMENTS**
- **SUMMARY**



GOLD FACTS: \$1,300 / OZ

- + The consumption of gold produced in the world is about 50% in jewelry, 40% in investments, and 10% in industry.



TREASURY METALS | ABOUT US

- + We are a leading exploration and development company in the Kenora Mining District.
 - Goliath Project: 1.7 million ounces with a clear path to growth
 - Goldcliff Property: Early exploration with high grade surface samples
- + TML's management and board have a successful record in building companies and developing world-class mining projects.
- + Treasury Metal's Goliath Gold Project is one of 6 gold mining projects in Ontario that is in the mine permitting process.
 - Treasury Metals – Goliath Gold Project (Dryden)
 - New Gold – Rainy River Project (Barwick)
 - Premier Gold – Hardrock Deposit Project (Geraldton)
 - IAMGOLD – Cote Gold Project (Timmins)
 - Osisko Mining Corp – Hammond Reef Project (Atikokan)
 - Argonaut Gold – Mangino Gold Project (Wawa)



TREASURY METALS - CORE VALUES AND RELATIONSHIPS

+ SAFETY

- Working safely is about “CARING FOR PEOPLE”
- Nothing we do is worth getting hurt over
- Working towards “Zero” recordable injury rate

+ ENVIRONMENT

- Responsible Stewards of the lands on which we operate

+ PEOPLE / STAKEHOLDERS

- Work for the mutual benefit of all Communities and Stake Holders
- Treat people with Respect and Dignity
- Demonstrate Ethical Behavior and Act with Integrity
- Act with Simplicity, Speed, Decisiveness



Doing the “Right Thing” because it is the “Right Thing To Do.”





TREASURY METALS – HIGHLIGHTS

- + Flagship high-grade gold project in Ontario
 - 1.7 million ounces in the combined category (Indicated and Inferred) from November 2011 resource estimate
- + Achievable nominal \$100 million CAPEX to produce 70,000 – 80,000 ounces per year for 10-year plus mine life
 - Excellent recoveries +95% by CIL and +92% by gravity/flotation
- + Funded to shovel ready stage including feasibility study and mine permitting
- + Significant infrastructure in place, highway accessible



DRYDEN

- + Population ~8,000, 7.6% unemployment;
- + Traditional dependency on forestry, recent closures;
- + Transportation and Service Hub on TransCanada highway;
- + Significant challenges related to economic restructuring and diversification.

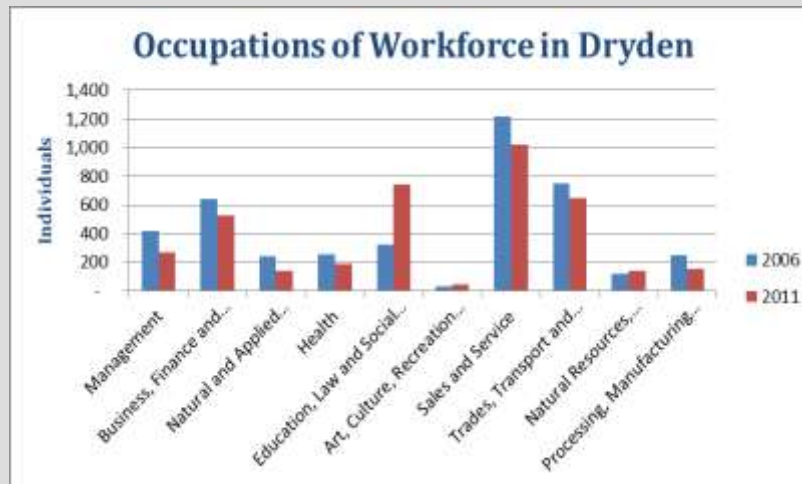

	Dryden		
	2006	2011	% Change
Total Population	8,195	7,617	-7%
Age 0-4	380	335	-11.8%
Age 5-14	1,070	865	-19.2%
Age 15-19	615	540	-12.2%
Age 20-24	465	410	-11.8%
Age 25-44	2,020	1,650	-18.3%
Age 45-54	1,350	1,325	-1.9%
Age 55-64	975	1,075	10.3%
Age 65-74	690	725	5.1%
Age 75-84	445	475	6.7%
Age 85 and over	180	215	19.4%
Median age of population	41.8	45.0	7.7%
Percent aged 15 and over	82.4%	84.2%	2.2%

Source: Statistics Canada, 2006 and 2011 Census Community Profiles



HISTORY OF GOLIATH GOLD PROJECT

GOLIATH GOLD PROJECT: *Path to Production*

Goliath Gold Project
Amalgamated by Uniting
Teck, Corona and
Laramide Deposits

2007 - 2008

Two Resource Estimates
and Preliminary Economic
Assessments (All NI 43-101
Compliant)

100,000+ Metres Drilled

2008 - 2012

Gold Mine Permitting
Begins and Exploration
Program Expansion

Full Feasibility Study
and Mine Financing

2012 - Present

*Gold Mine
Production*

Environmental Baseline Studies



PROJECT LOCATION

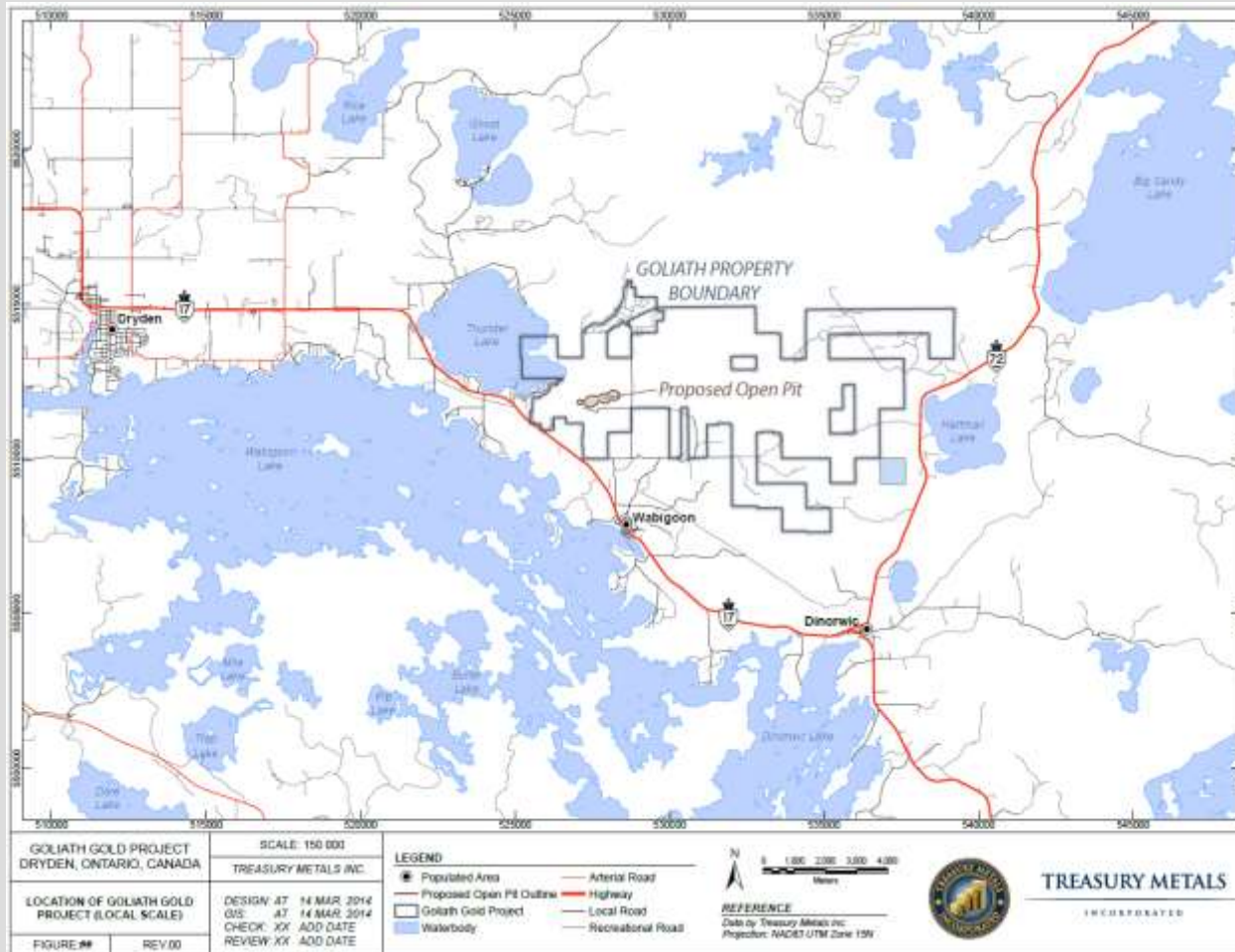

PROJECT STATUS



MINING INTRODUCTION

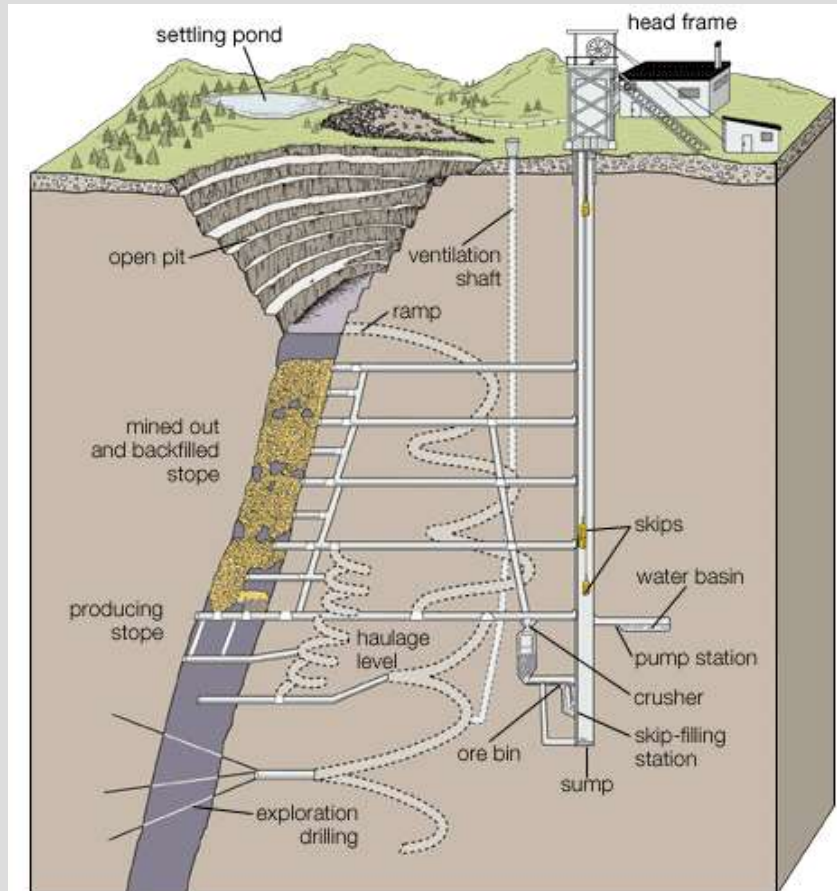

© 2007 Encyclopædia Britannica, Inc.

Source: H. Hamrin, *Guide to Underground Mining Methods and Applications* (Stockholm: Atlas Copco, 1997)



PROCESSING PLANT

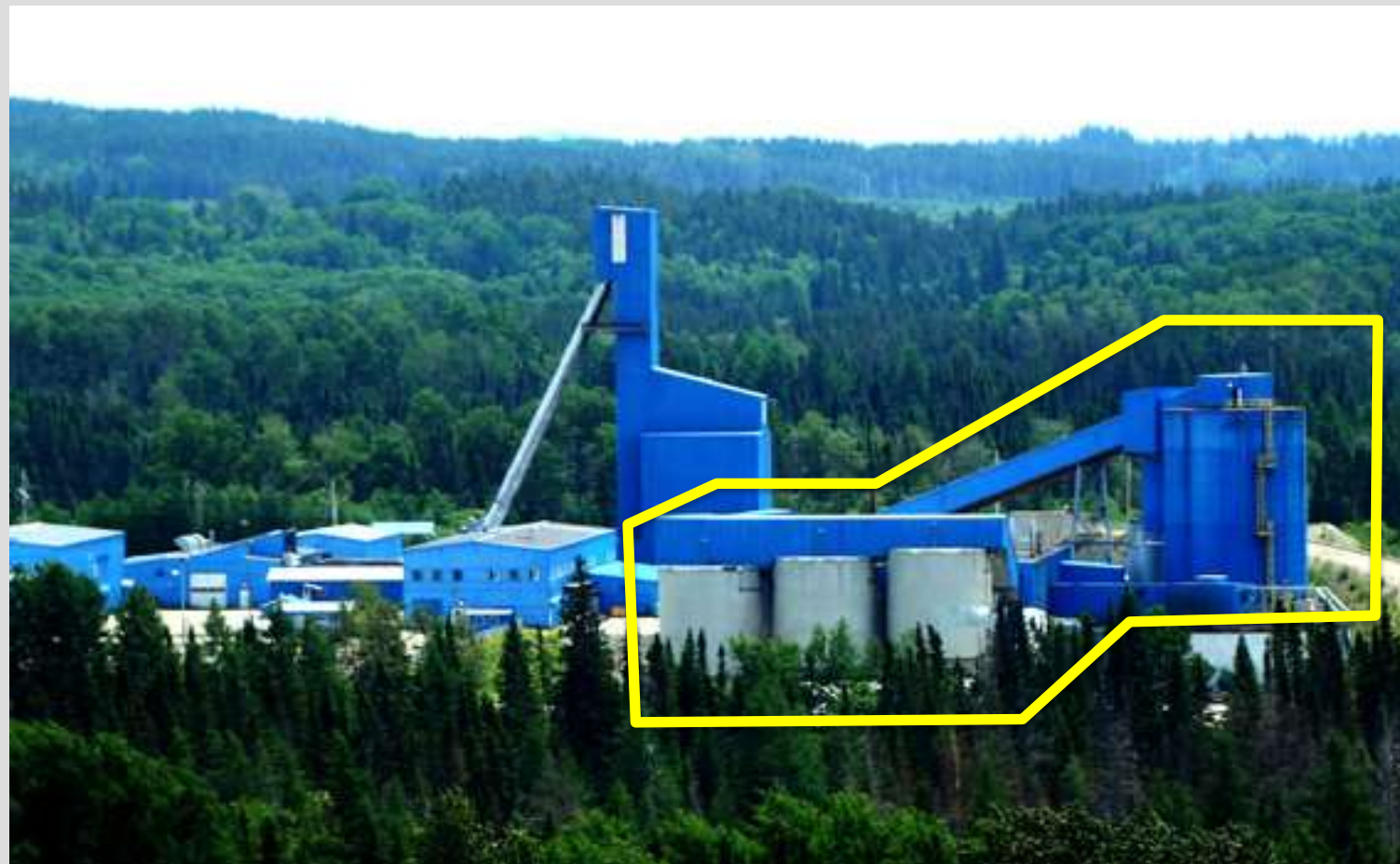

MILL PROCESS

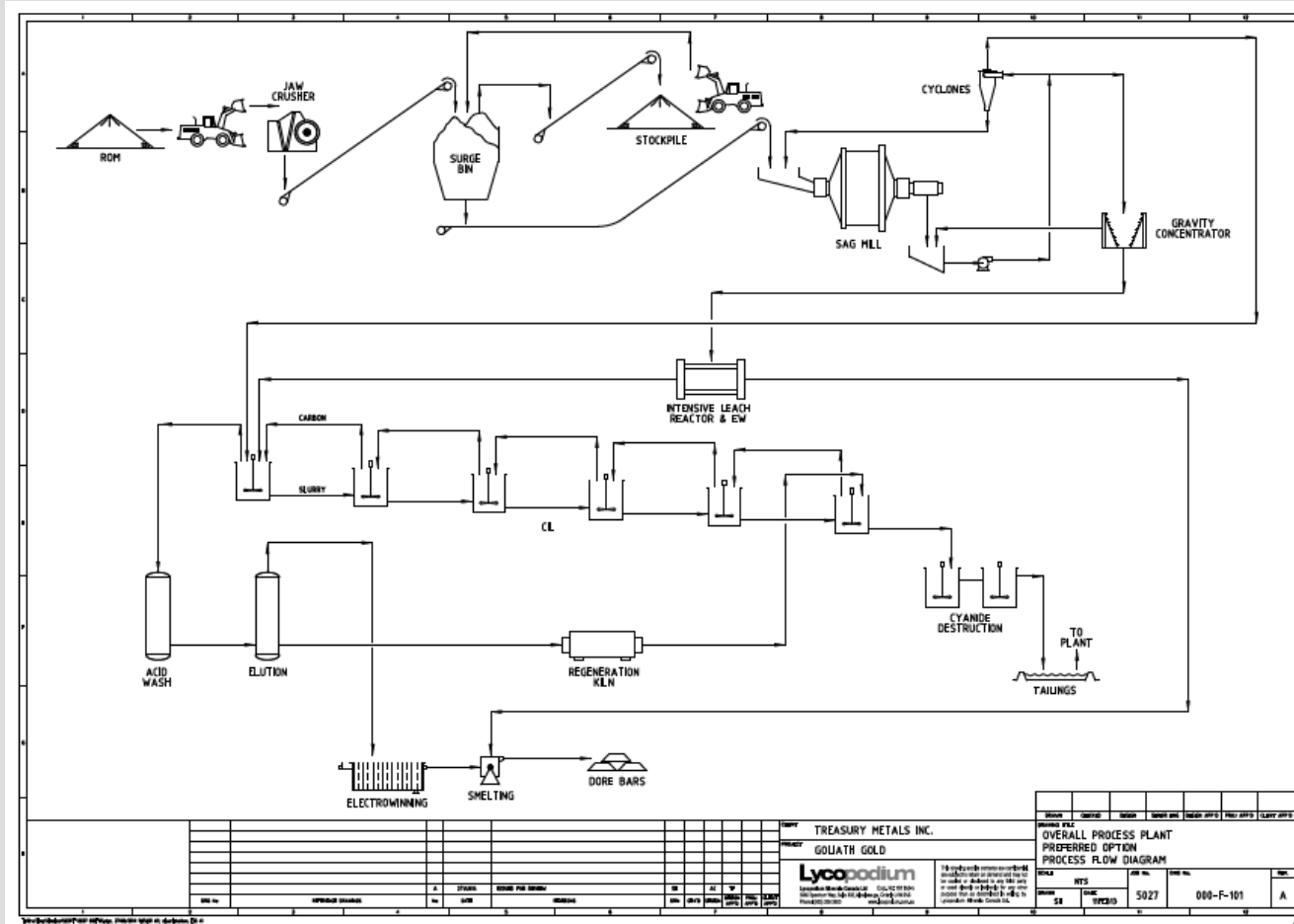

INFRASTRUCTURE IN PLACE

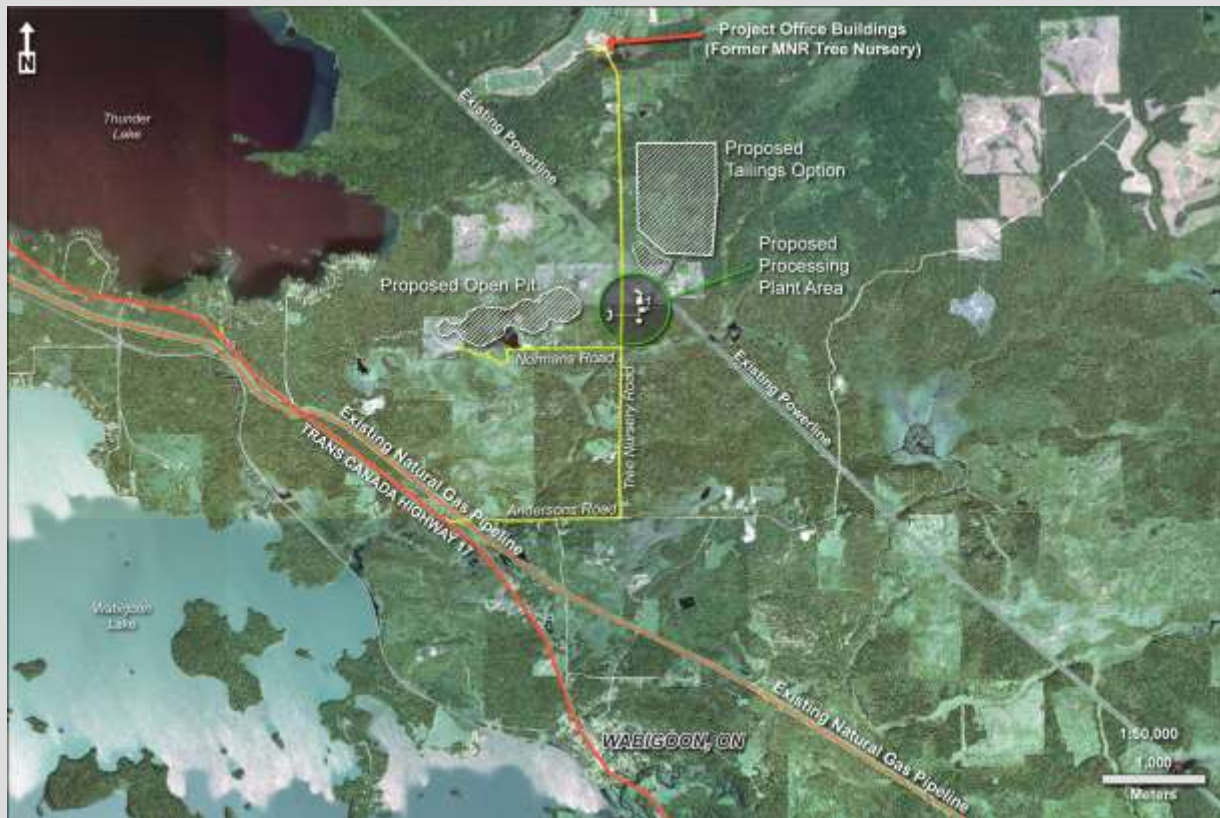

- + NW Ontario provides excellent infrastructure – reducing costs.
- + Power, local workforce and transportation all readily available.
- + Historical industrial offices are now TML's exploration and development site.
- + Power sources on-site: gas and electric power lines.



GOLIATH SITE PLAN



MINING PLAN

- + ~3 g/t Au Eq Average Mill Feed (3 parts per million)
- + \$1375 Gold Price
- + 4.5 Million Tonnes OP, 4.5 Million Tonnes U/G
- + 70,000 – 80,000 ounces/year, 2100 - 2700 t/day milling
- + 130-180 m. Final Pit depth. 500-600 m. Underground Depth
- + Capex: \simeq \$ 100 MM
- + Total Mine Life: 10 – 12 years (5 open pit/ 5 UG)



MAJOR STUDIES – SUPPORTING DEVELOPMENT

- + Tetra Tech WEI
 - Coordination of the Environmental Impact Statement.
- + Lycopodium Minerals Canada
 - Development of process options;
 - Infrastructure and design layout;
 - Water balance and treated water discharge characterization.
- + WSP Canada
 - Design of the Tailings Storage Facility.
- + P+E Mining Consultants
 - Mine design and mine plan.



PROJECT TIMELINE

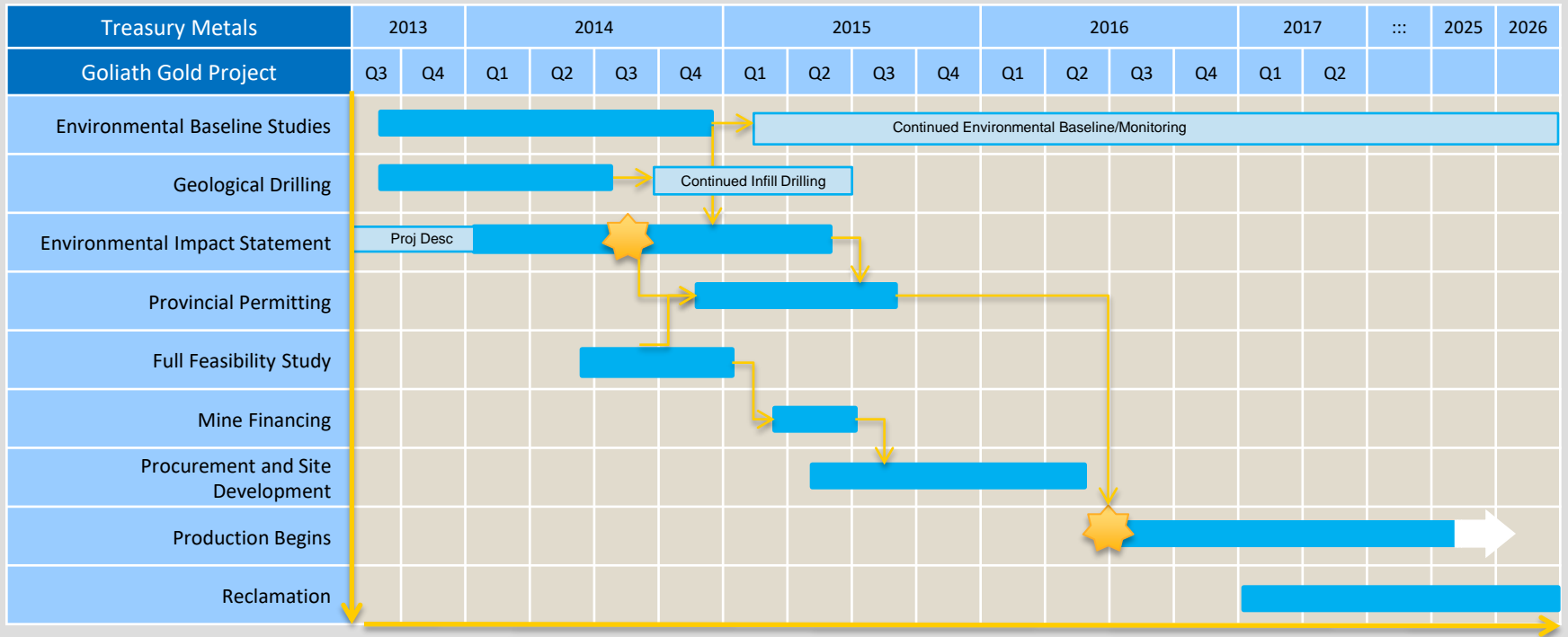

GEOLOGY



GEOLOGICAL SETTING

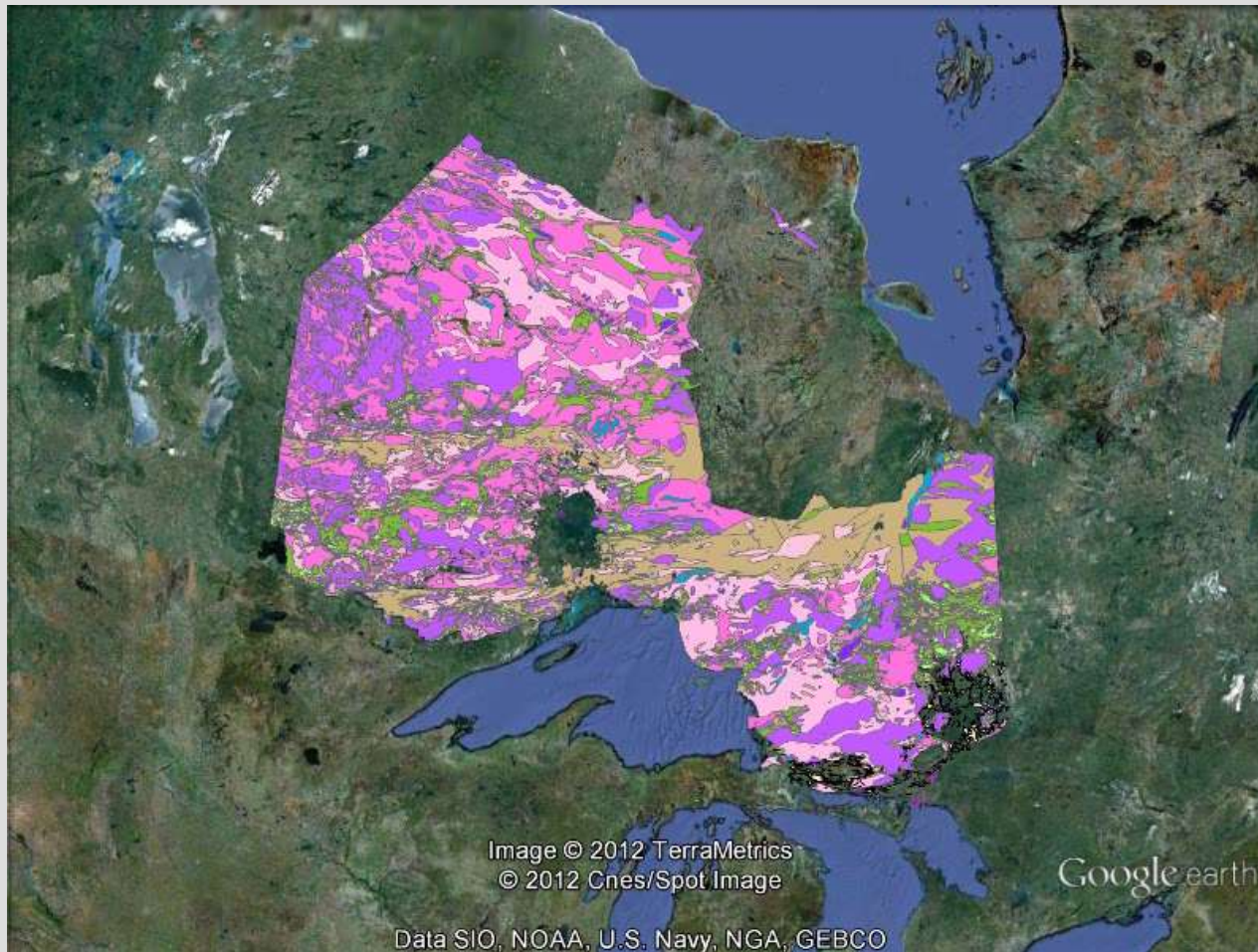

TML GEOLOGY AND ALTERATION

TML has two main rock types we intersect in the resource area:

- + Muscovite-sericite schist (MSS)
- + Biotite-muscovite schist (BMS)

Other rock types include:

- + Metasediments
- + QFP
- + Mafic Dykes
- + Iron formation
- + Biotite schist
- + Amphibolite



MINERALIZED MSS IS THE KEY

+ Key minerals:

- Sphalerite
- Galena
- Best concentrations occur proximal to upper and lower MSS contacts

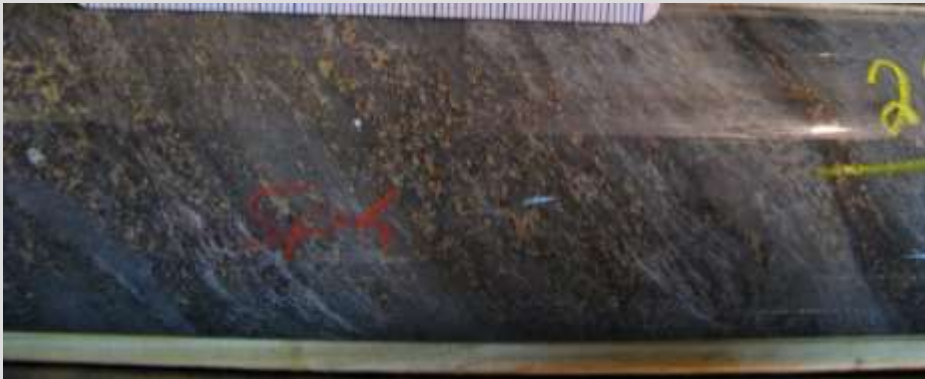

OUR IDEAL SCENARIO

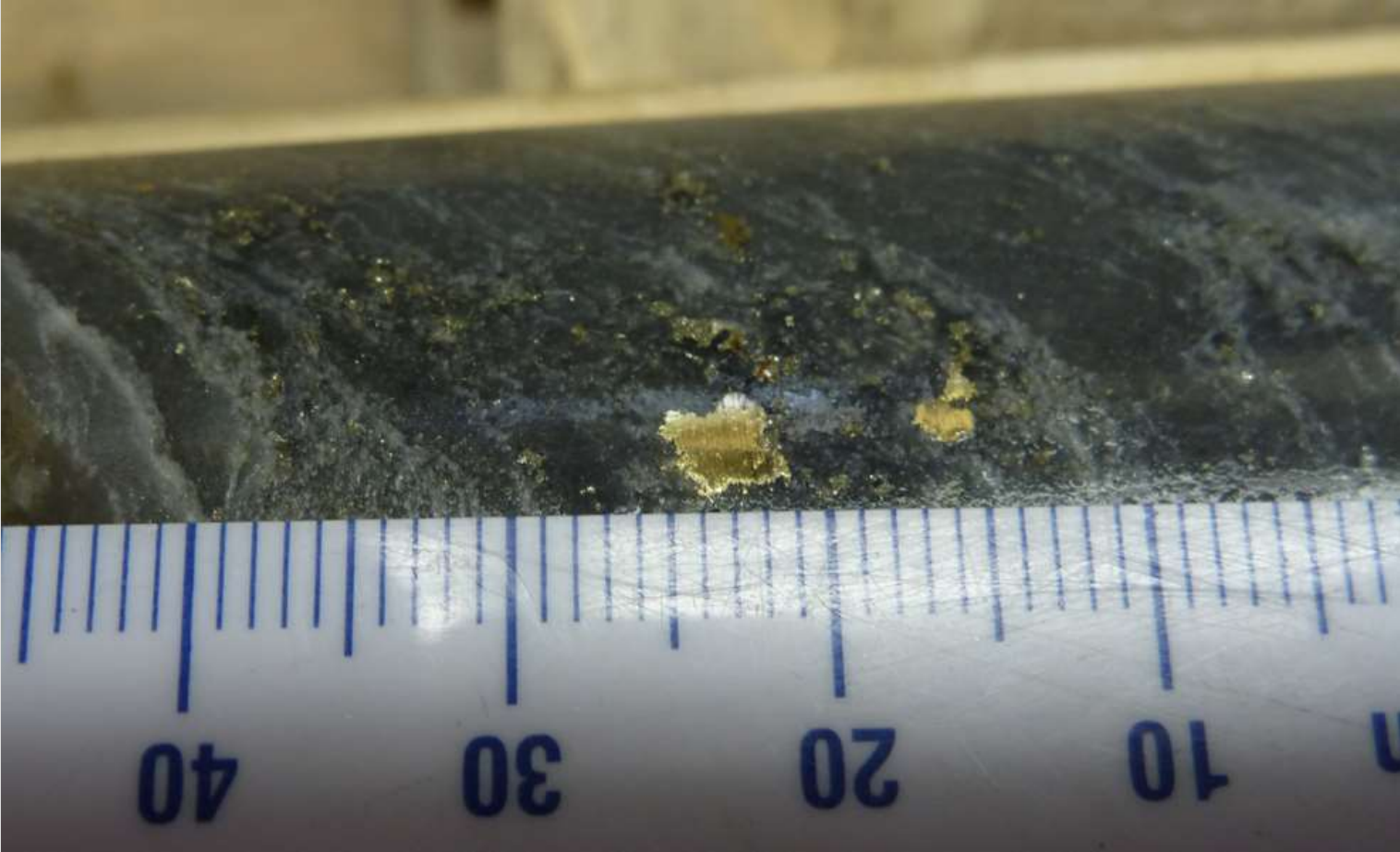

MINERALIZED ZONES

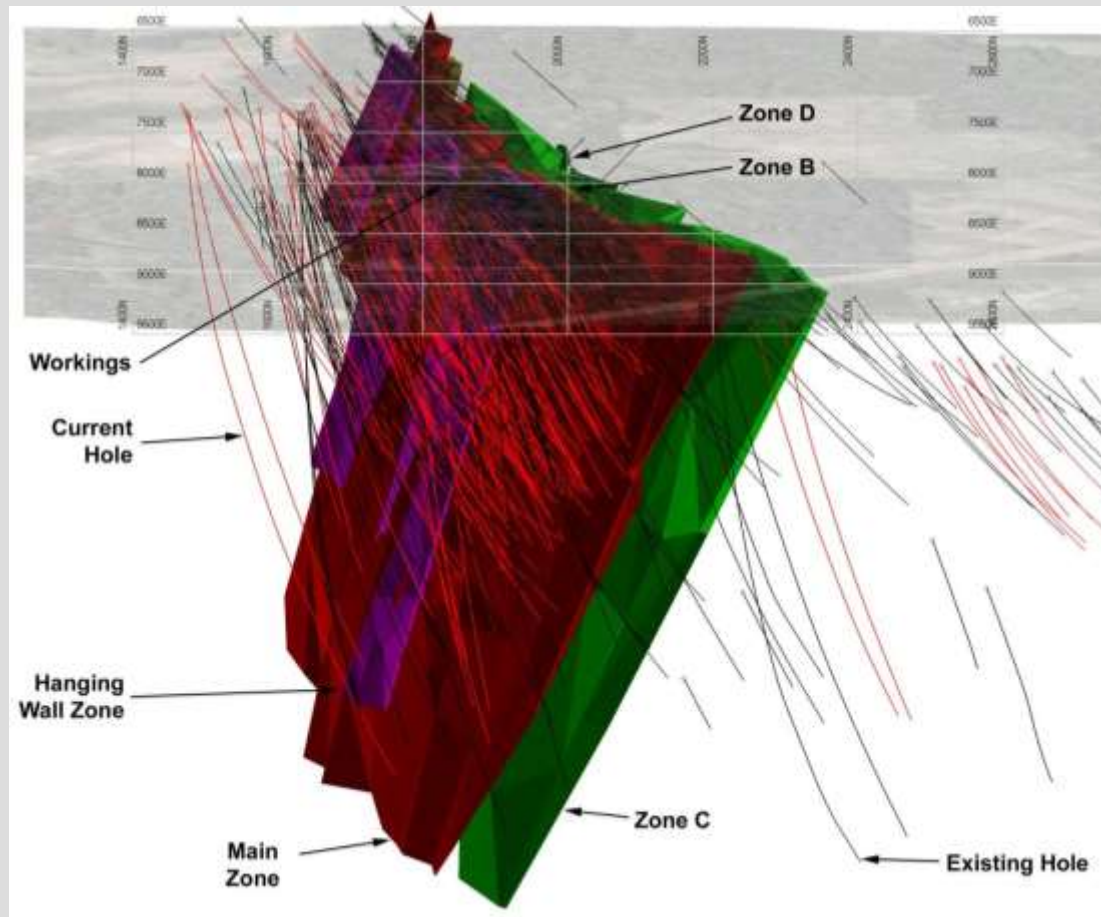

OPEN PIT

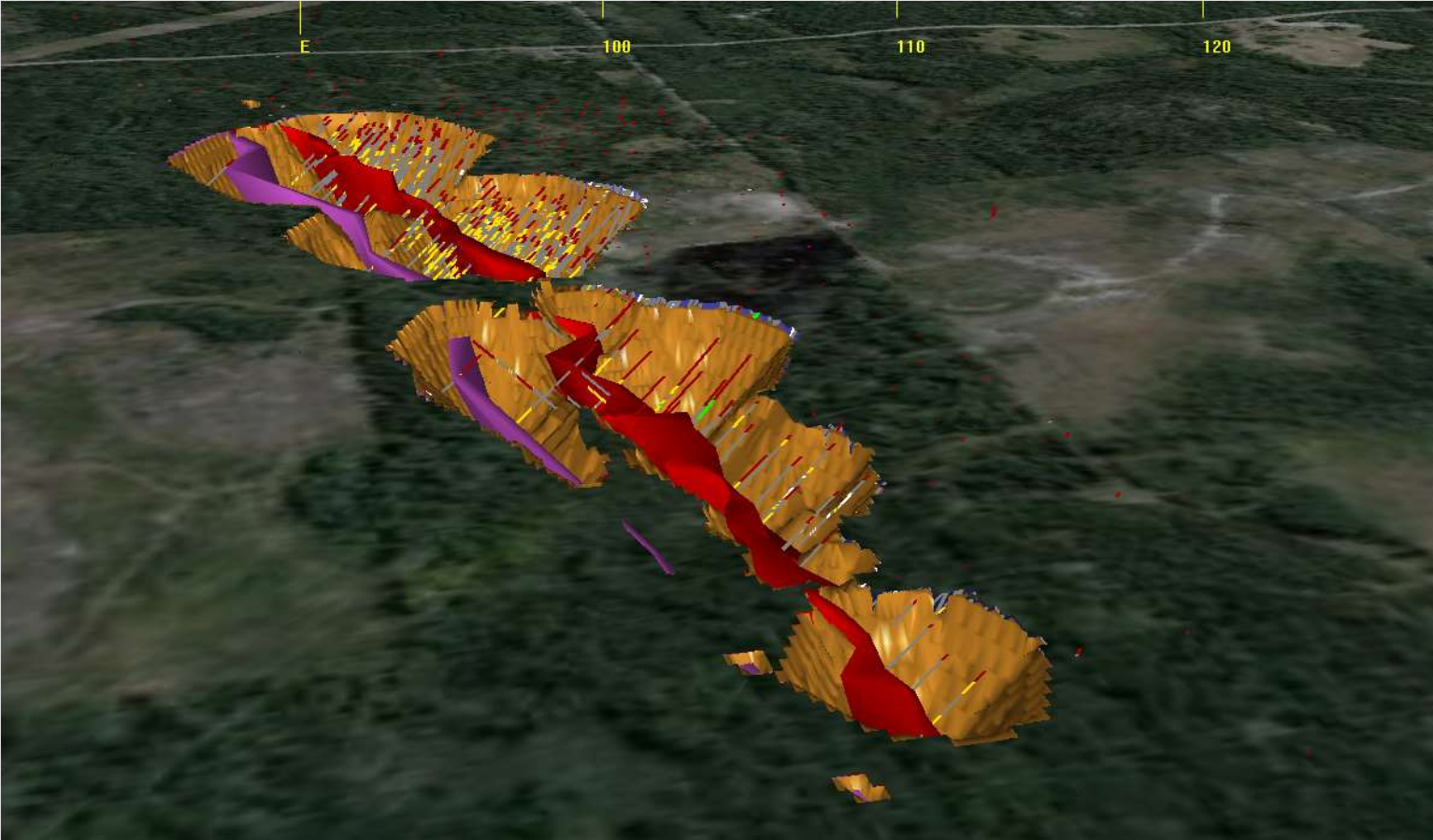

MAIN ZONE LONG SECTION

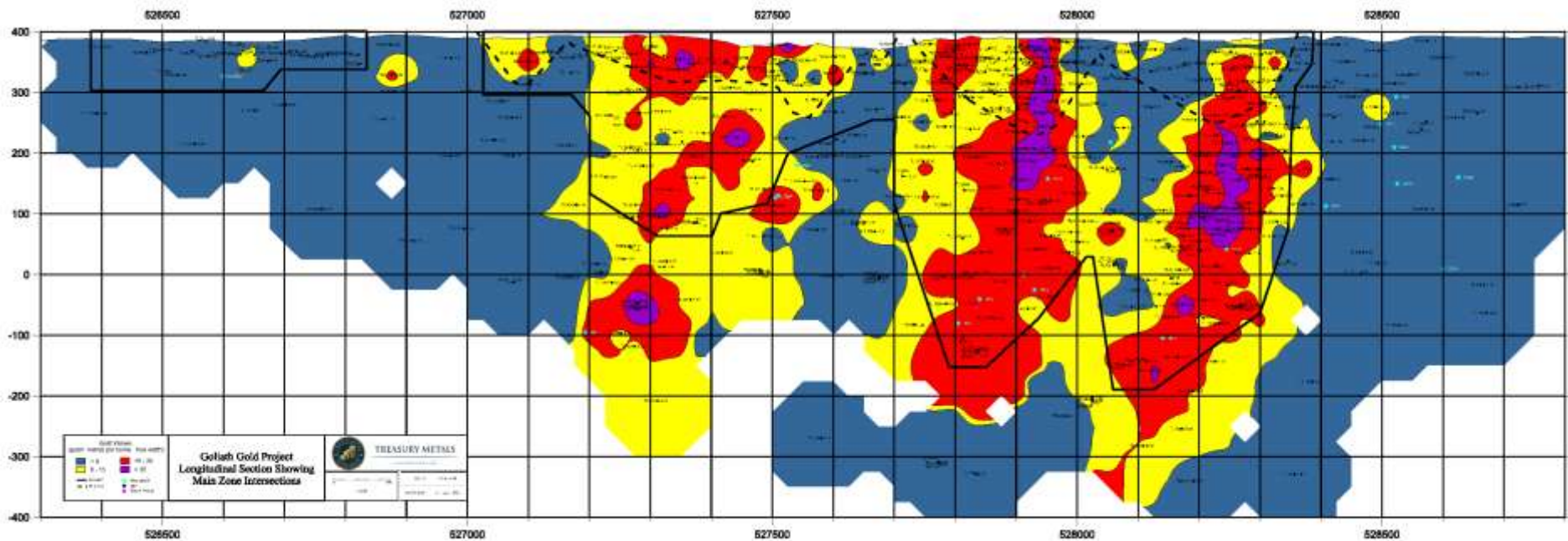

C ZONE LONG SECTION

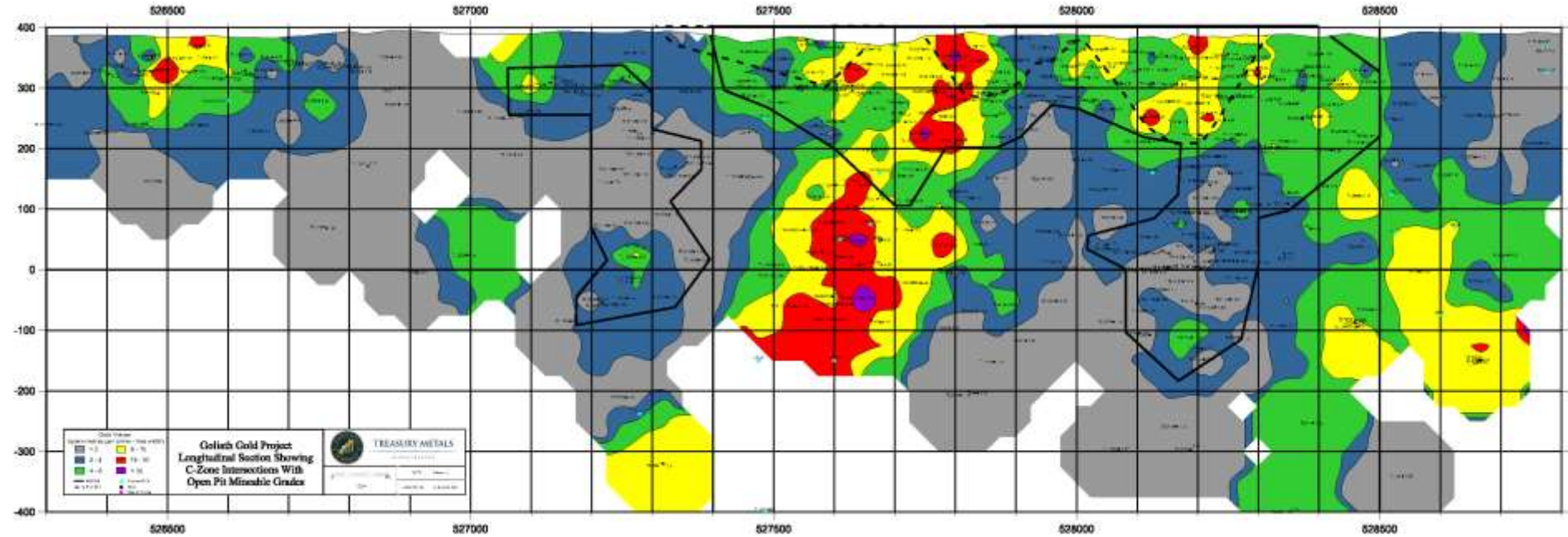

ENVIRONMENTAL PROGRAM AND PERMITTING





ENVIRONMENTAL ASSESSMENT PROCESS AND PERMITTING

+ Federal

- Canadian Environmental Assessment Agency (CEAA).
 - Triggers include ore processing greater than 600 tonnes per day and the potential to disturb fish habitat.
 - Environmental Impact Statement will be completed as part of federal regulations.

+ Provincial

- 40 + individual permits may be required.
- Permits will be approved based on provincial regulatory requirements (Class environmental assessment).



BASELINE STUDIES

- + 2010-2014 fieldwork has been completed with operational team of DST, TBT, AMEC, EcoMetrix, KCB, gck, Keewatin-Aski and Treasury Metals personnel.
- + Studies include:
 - Surface Water and Hydrology
 - Aquatics and Fisheries
 - Wetlands
 - Terrestrial Wildlife
 - Noise, Light and Dust
 - Archaeology
 - Soils and Vegetation
 - Hydrogeology
 - Socioeconomic
 - Geochemistry / Geotechnical



STUDY AREA

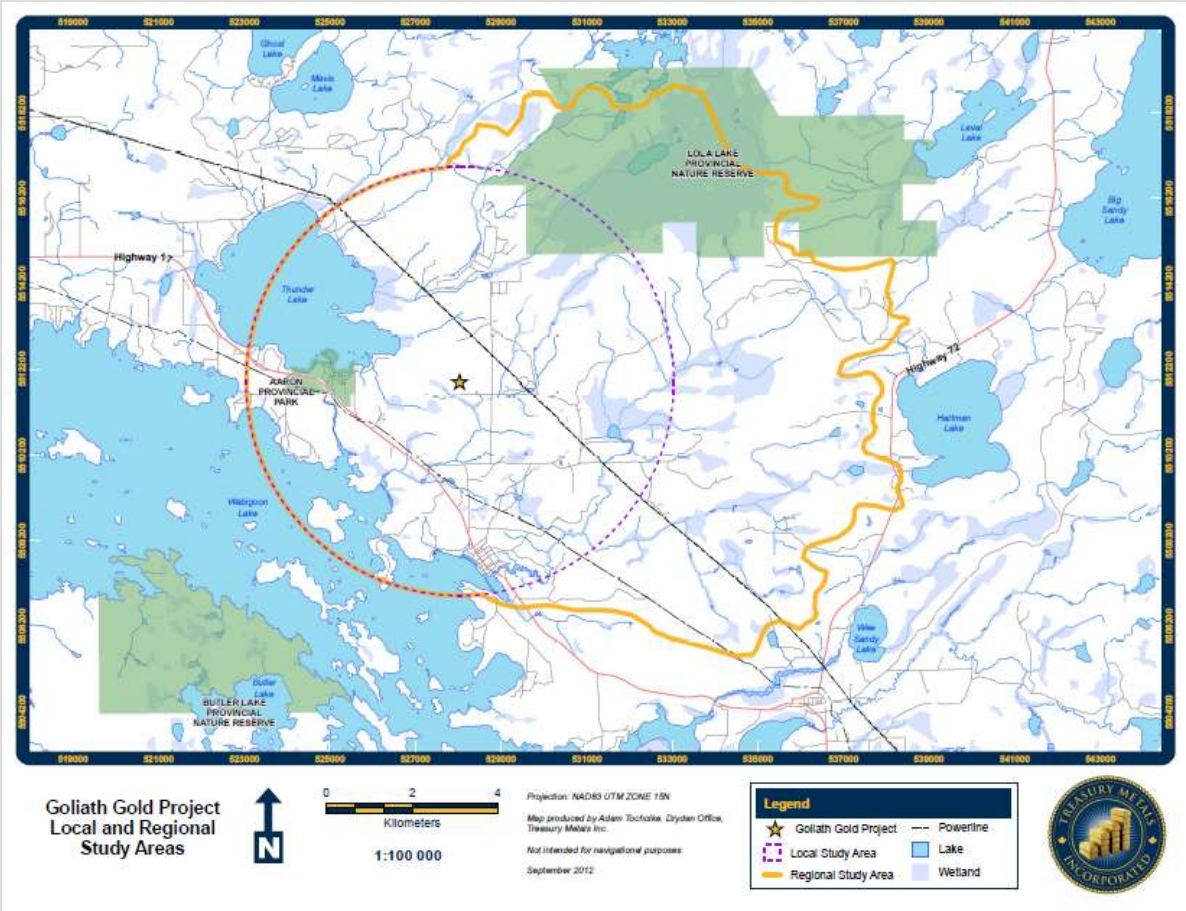



ENVIRONMENTAL PROGRAM OVERVIEW

- + Environmental baseline studies have been completed to:
 - Understand the natural environment before development;
 - Support mine design and development decisions;
 - Support monitoring during operations and final closure plan decisions.
- + Treasury's environmental program is on schedule, providing the data necessary to support the Company's environmental permitting activities with the Federal and Provincial governments.



SOCIO-ECONOMIC IMPACT AND BENEFITS





COMMUNITY OWNERSHIP

- + Goliath Gold Mine
 - Built in N.W. Ontario by N.W. Ontarians.
- + Hire Locally
 - Where labour force and skills are available;
 - Develop sector specific skills and capacity working with Educational Institutes, First Nations, and other local industries.
- + Purchase Locally
 - Purchase goods and services from Dryden and local businesses, assuming competitive pricing and service.
 - Mine construction;
 - Seek to use N.W. Ontario construction services.



SOCIAL AND ECONOMICAL IMPACTS

	Current	Future
Direct Employment	20	200
Indirect Employment (4:1 Multiplier)	80	800
Total Employment Impact	100	1000

- + In 2012 TML supported over 75 Northwestern Ontario businesses with over 70 based in Dryden.

TML Total Vendor Spending 2012	\$ 5.9 Million
Northwest Ontario	\$ 4.3 Million



REGIONAL HUB

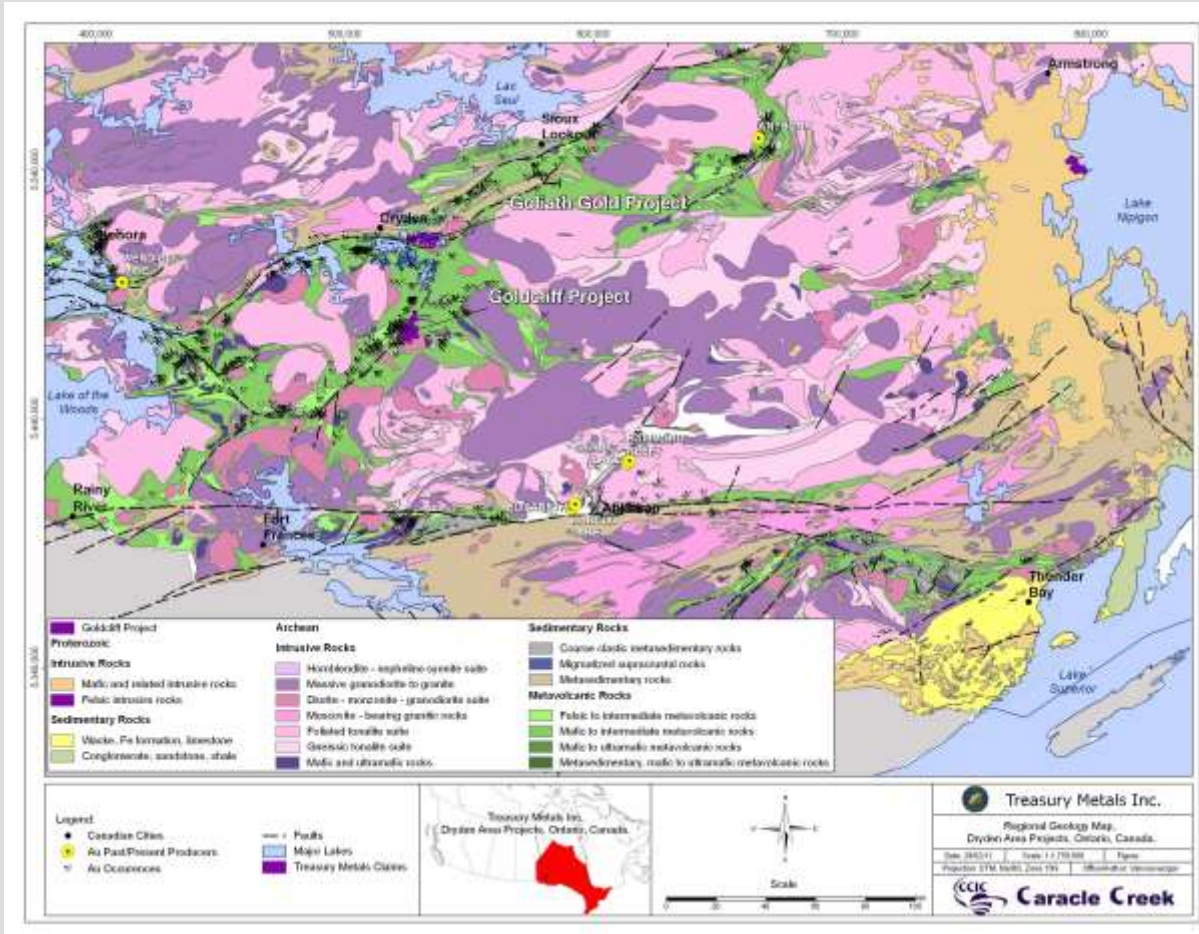

EMPLOYMENT TRAINING AND BUSINESS OPPORTUNITIES



TREASURY METALS – JOB QUALIFICATIONS

JOB	GRADE 12	COLLEGE DIPLOMA	UNIVERSITY DEGREE	TRADES CERTIFICATION	OTHER
FIELD TECHNICIAN	✓				
UNDERGROUND MINER	✓				✓
ASSAY LAB TECH	✓				
HEAVY EQUIPMENT OPERATOR (MTCU Transcript)	✓				✓
ADMINISTRATIVE TECH	✓	✓			
ENVIRONMENTAL TECH	✓	✓			
HEAVY DUTY EQUIPMENT TECH (MTCU)	✓	✓		✓	
ELECTRICAL/INSTRUMENTATION & CONTROL TECHNICIAN (MTCU)	✓	✓		✓	
MULTI-TRADES CRAFTSPERSON (MTCU)	✓	✓		✓	
GEOLOGIST	✓		✓		
MINE ENGINEER	✓		✓		
MINE MANAGER	✓		✓		



TREASURY METALS – BASIC HIRING CRITERIA

- + Basic Requirements and Reasoning:
 - Minimum Grade 12/GED
 - Higher level education for specialized positions (Grade 12/12 Math and English);
 - Specialized skill requirements* and use of technology;
 - Comprehension, report writing.
 - Valid Drivers Licence
 - Drive company vehicles on and off road.
 - Pre-employment Drug Test
 - Safety for self and others;
 - Working with and around heavy equipment and machinery.
 - Criminal background check.
 - Screen-out undesirables;
 - Reduce risk to employees and property;
 - Harassment free workplace.

*Note: All training through recognized training institute or MTCS.



SUMMARY

- + Treasury is committed to working with local municipalities and stakeholders.
- + Treasury is committed to forgoing partnerships with local First Nation communities.
- + 2014 is another busy year with further exploration work, environmental permitting activities, and other Project studies.
- + Treasury Metals goal is to be:

*Partners in Economic Development with our local
Municipalities, and Aboriginal communities.*





Questions ?

